

SPLIT SET® Stabilizers SS-33

Specifications and performance

The Split Set stabilizer is a slotted steel tube, with one end tapered for easy insertion into a drill hole. The other end has a welded ring flange to hold the bearing plate.

The stabilizer is inserted into a hole slightly smaller in diameter than the tube, using a simple driver tool fitted to the drill. As the tube enters, its diameter is compressed and the slot partially closes. This exerts radial forces along the length of contact with the rock, providing the friction which

holds the rock together. The driving force of the drill actively loads the bearing plate against the rock.

International Rollforms' Split Sets feature a patented "Ring Indexing" feature. This allows for determining the length of an installed Split Set.

Tubes and plates are available standard or galvanized, made in accordance with ASTM F 432-95 where applicable. Code stampings on the tube show its size, date and place of manufacture, and heat lot of steel.



Model SS-33 Split Set stabilizers are 1.3 in. (33 mm) in diameter.

Stabilizers are packaged 6 per pack and 300 per pallet.

Also see Utility Hangers on page 2.

SS-33 tube		Standard		Galvanized	
Length Inches (mm)	Weight Lb. (kg)	Comm No.	Weight Lb. (kg)	Comm No.	
30 (762)	2.7 (1.2)	90322835	2.9 (1.3)	90322850	
36 (914)	3.2 (1.4)	72237936	3.4 (1.5)	90321688	
42 (1067)	3.7 (1.7)	90322843	4.0 (1.8)	90322868	
48 (1219)	4.3 (2.0)	72237944	4.6 (2.1)	90321696	
60 (1524)	5.3 (2.4)	72237951	5.7 (2.6)	90321704	
66 (1676)	5.8 (2.6)	90321316	6.2 (2.8)	90321712	
69 (1753)	6.1 (2.8)	90322264	6.5 (3.0)	90322512	
72 (1829)	6.4 (2.9)	72237969	6.8 (3.1)	90321720	
84 (2134)	7.4 (3.4)	72237977	7.9 (3.6)	90321738	
96 (2438)	8.4 (3.8)	72237985	9.0 (4.1)	90321746	

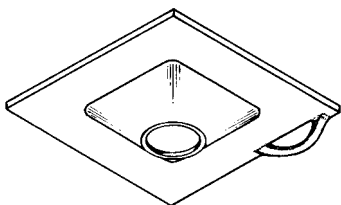

SS-33 domed plate		Standard		Galvanized	
Dimensions Inches (mm)	Weight Lb. (kg)	Comm. No.	Weight Lb. (kg)	Comm. No.	
6 x 6 x 0.16 (150 x 150 x 4)	1.6 (0.7)	90320250	1.7 (0.8)	90322447	

Domed bearing plate

Split Set domed bearing plates uniquely combine high strength with light weight, and are integral parts of the Split Set system. International

Rollforms plates meet ASTM F 432-95 standards where applicable, providing a load capacity of 10 tons (9.1 metric tons) with minimal deflection.

Installing the SS-33 stabilizer

The SS-33 tube has a nominal outside diameter of 1.3 inches (33 mm). The length chosen should be the same as with other types of rock bolts, and installed with the same spacing.

The stabilizer is installed with the same drill used to make the hole. Split Set stabilizers are commonly installed with jacklegs, stopers, jumbos and automatic bolting machines. Almost any hydraulic drill, or any percussive air drill with a bore of 2-5/8 inches (66 mm) and operating at 90 psig (6 bar), will have sufficient impact.

SS-33 drivers Standard	Shank size		Weight Lb. (kg)	Comm. No.
	Inches	(mm)		
Short-nose	7/8 x 4-1/4	(22 x 108)	2.5 (1.1)	72243405
Long-nose	7/8 x 4-1/4	(22 x 108)	2.8 (1.3)	90324518

SS-33 drivers Rope-threaded	Steel size		Weight Lb. (kg)	Comm. No.
	Inches	(mm)		
Short-nose	1	(25)	1.9 (0.9)	90321019
Long-nose	1	(25)	2.2 (1.0)	90325507

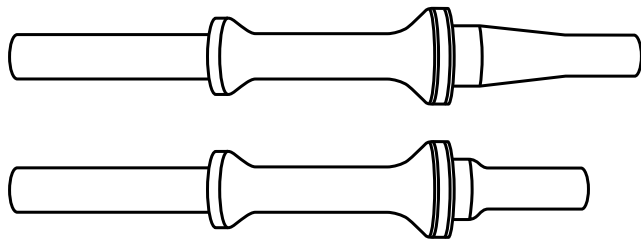

Typical long-nose and short-nose drivers

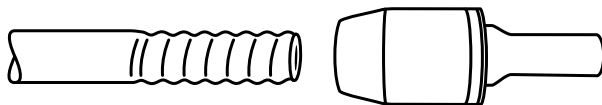

Typical rope-threaded driver

SS-33 driver tools

A simple driver tool adapts the drill for easy stabilizer insertion. One end fits the tube; the other fits the drill chuck or drill steel.

All genuine Split Set driver tools are made of high-strength heat-treated alloy steel, designed for long life, and precision-made for the proper fit.

For jackleg or stoper insertion, a long-nose or short-nose driver tool may be used. The short-nose tool is also used for driving an SS-33 Split Set utility hanger inside an installed SS-33 Split Set stabilizer.

Rope-threaded drivers are available to fit drill steel for jumbos and bolters, and for long reach with jacklegs and stopers.

SS-33 utility hangers

Split Set utility hangers are available in 18 and 24-inch (46 and 61-cm) tube lengths to support light loads such as cables, vent tubing, and pipes.

Also, utility hangers can be driven inside installed Split Set stabilizers, by aligning the hanger slot with that of the stabilizer. This permits easier installation of mesh, after the ground is secured by the stabilizers.

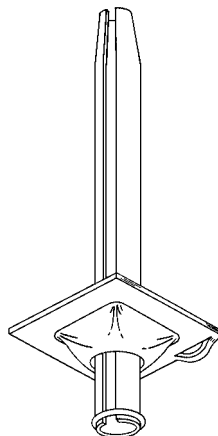

SS-33 utility hangers			
Length In. (mm)	Weight Lb. (kg)	Comm No.	
<i>Standard</i>			
18 (457)	1.7 (0.8)	90321076	
24 (610)	2.2 (1.0)	90321324	
<i>Galvanized</i>			
18 (457)	1.8 (0.8)	90321662	
24 (610)	2.3 (1.0)	90321670	

SS-33 installation and pull testing

Bit selection and drilling

To select the correct drill bit diameter for meeting the recommended initial anchorage of 3 to 6 tons, drill several holes with bit diameters ranging from 1-3/16 to 1-5/16 inch (30 to 33 mm). Drill each hole at least 2 inches (5 cm) longer than the bolt length. Number each hole and record the bit size. (In soft ground, a bit may drill a hole larger than its diameter. In hard abrasive ground, the hole may be the same diameter as the bit.)

Drive into each hole an SS-33 Split Set stabilizer fitted with a pull collar and spacer as shown. Record the driving time for each stabilizer. After insertion, observe the amount of slot closure inside each stabilizer.

SS-33 pull collar and spacer set	Weight	Comm. No.
	lb.	(kg)
	0.4	(0.2)
		90320888

To determine anchorage, perform a pull test (page 4). Align the pull tester with the stabilizer, and pressurize it until the stabilizer slips in the hole.

Watch to be sure that it is actually the stabilizer that has slipped. When building up the pull load on the stabilizer, various adjustments may occur such as realignment of the tester housing, bearing plate settling, or localized rock crushing. These must not

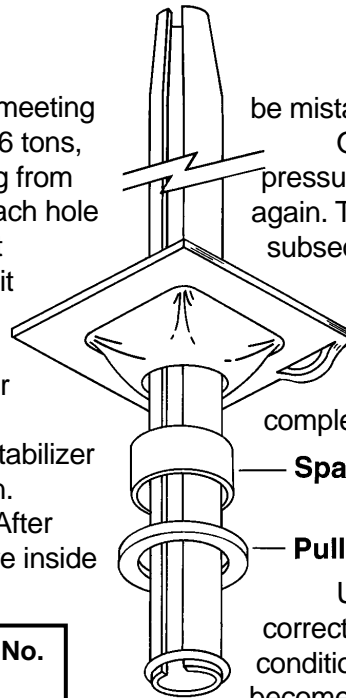

be mistaken for tube slippage.

Once the bolt has slipped in the hole, pressurize the tester pump until the bolt slips again. The same pull load should cause subsequent slippage.

Interpreting test data

After the above pull tests are completed, draw two graphs:

(a) Anchorage versus bit diameter.

(b) Anchorage versus driving time.

Use the first graph to determine the correct bit size for your particular ground condition. As the bit wears, the hole will become smaller and friction will increase until the bit is replaced or the drill can't drive the bolt completely.

Use the second graph to establish correct driving time required for this ground and bolt length. With a given bit, drill, bolt length, rock characteristic and constant pressure, insertion time will be proportional to initial anchorage.

It's important to establish this data for use in later spot checks, to assure that proper installation techniques are still being used.

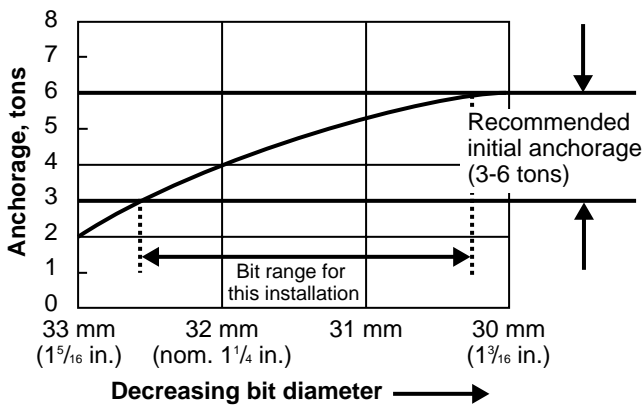

(a) Anchorage versus bit diameter

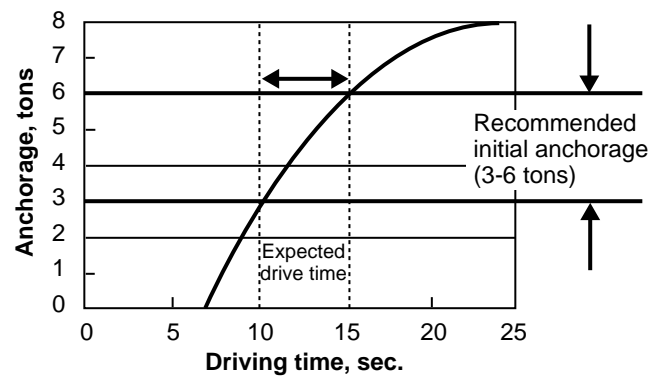

(b) Anchorage versus driving time

SS-33 pull tester			
Description	Weight		Comm. No.
	Lb.	(kg)	
Pull tester assembly	27.6	(12.5)	90320904
Mechanical portion	11.9	(5.4)	90321290
Hydraulic portion	15.7	(7.1)	90321415
<i><u>Hydraulic parts</u></i>			
Cylinder	7.0	(3.2)	90320177
Gage	1.5	(0.7)	90320193
Pump	5.0	(2.3)	90320169
Hydraulic hose	2.0	(0.9)	90320185
Gage adapter	0.2	(0.1)	90320201
<i><u>Mechanical parts</u></i>			
Claw	3.3	(1.5)	90320896
Housing	5.5	(2.5)	72233422
Bushing	1.0	(0.5)	72233430
Spindle	1.8	(0.8)	72233414
Hex nut	0.3	(0.1)	95084778

SS-33 pull test equipment

The pull tester consists of two assemblies: the hydraulic portion which includes the cylinder, gage, pump, hose and adapter; and the mechanical portion which includes the claw, housing, U-shaped bushing, spindle and nut.

With the bushing removed, the claw can be slid over the pull collar which has been installed with the stabilizer. When the housing and cylinder are raised, the bushing can be inserted between the nut and the cylinder. The nut is then tightened to take up slack.

The pump is then actuated to raise cylinder pressure, pulling the stabilizer slightly out of the hole through the bearing plate.

Maximum gage reading at slip indicates the holding force. The device can be used for slip loads up to 12 US tons (10.9 metric tons).

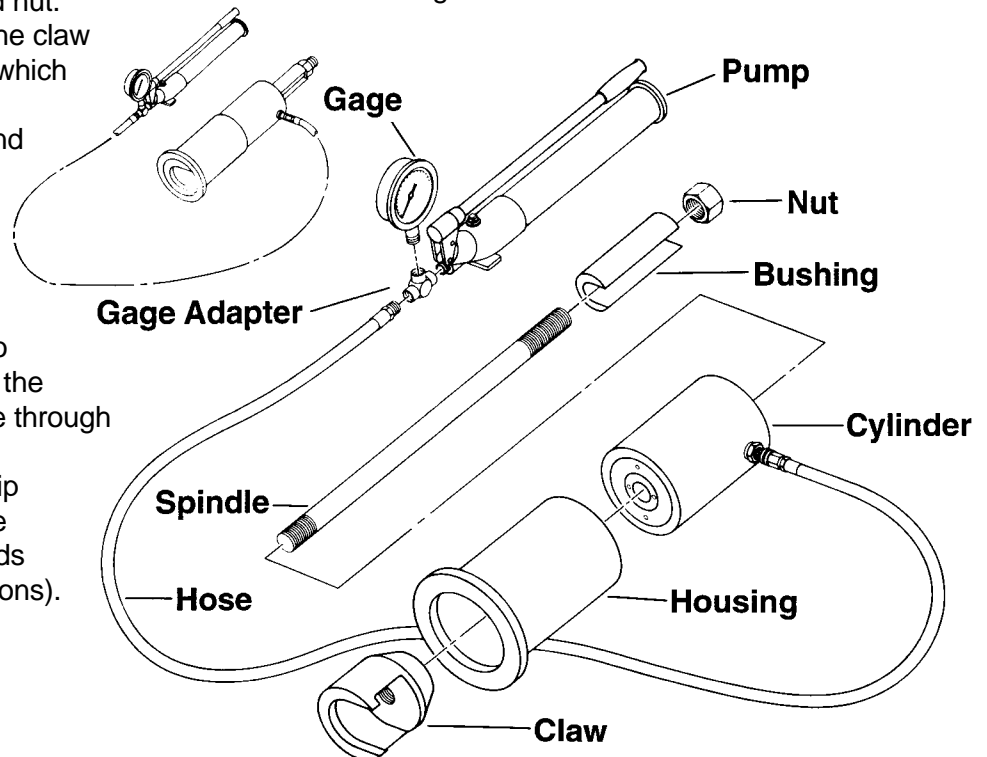

Application Engineering Service

The Split Set stabilizer is a unique rock stabilization and support system. It interacts with the rock differently from other rock bolts. For this reason, the Split Set Group offers a free application engineering service to assist you in the selection of the proper Split Set configuration for your needs. We will also assist in determining the best way to use your existing equipment for the job, the best drilling procedure, and appropriate tools and accessories for your equipment and space limitations.

We urge you to take advantage of this service. Our sales representative will be pleased to make the arrangements.

Nothing contained in this brochure is intended to extend any warranty or representation, expressed or implied, regarding the products described herein. Any such warranties or other terms and conditions of sale of products shall be in accordance with International Rollforms' standard terms and conditions of sale for such products, which are available upon request.



International Rollforms, Inc.

P.O. Box 5426
Deptford, NJ 08096

Phone: 1-888-561-4200 or
Fax: 1-856-401-8583